

MOUSAVI
Classic Catalog 2024

Mojtaba Mousavi



Mohammad Mousavi



Morteza Mousavi



Mousavi Groups Leaders

| We design, manufacture and can install high quality Stone products

Mousavi Stone Group is part of Mousavi Bros Ltd., a family owned business established in 1981. We are one of the Iran leading stone specialists, and offer you a comprehensive service to manufacture, supply and install high quality custom made products throughout the Iran, as well as supplying a range of standard products from Stock

To ensure you get the best stone, great emphasis is placed on both high product quality and outstanding customer service. Our stone products are use from a best Material, and is cost-effective and offers consistent quality and colour. This means you can use our products with confidence in a very wide range of applications, including residential, retail, commercial, religious, self-build, as well as restoration projects where stone detailing is required.

| What you can expect from Mousavi Stone Group at a glance

- Outstanding expertise in stone with over 30 years' of manufacturing excellence
- The ability to create custom designed products in virtually any stone colour
- Design advice in conjunction with using your architects' drawings
- Standard products kept in stock
- Full Iran and Overseas coverage from our central base
- Expertise in all building types including residential, commercial, retail and religious
- Our own Designing, Making, Executing is a key factor in providing you with very high quality products and great value for money





Mr. Yousefian Project (Iran, Kerman, Meysam St.)

• Producer & The Contractor: Mousavi Group • The Employer & Architecture : Mr Yousefian



| Some details of the project



Building facade rendering



Facade of building

Emarat Sefid (Iran, Kerman, 12th Meysam St.)

• Producer & The Contractor: Mousavi Group • The Employer: Mr Abdolalizade • Architecture : Mr. Molai



We split our services into 6 main areas...



| Some details of the project

| How we work for you

Mousavi Stone Group aim is to provide you with a full suite of services and to ensure that your experience with us is complete, efficient and as hassle-free as possible.



Mr Harandi Project (Iran,Kerman, 11th Meysam St.)

• Producer & The Contractor: Mousavi Group • The Employer & Architecture : Mr. Harandi

1. Technical consultation

Our technical staff provide free help to architects, other specifiers and self-builders in order to ease the selection and design of all stone features. Involving us at an early stage in a project ensures that all issues can be taken into account such as design, technical performance and budget parameters, as well as scheduling deliveries to suit building programme requirements. Our team has many years experience, and this can be invaluable to our customers. This is helpful because for many of the people we deal with, stone features are a very infrequent purchase – or, for some, may even be a one-off purchase. As a consequence, this relatively specialist building product is not something which everyone knows a great deal about, and therefore having technical experts on hand is obviously very important and useful.

Our technical consultation service provides:

- Initial advice on the suitability of stone for the project
- More detailed input on design for specific features
- Site meetings
- Final specification on all features needed
- Production and delivery scheduling – plus installation option



| Some details of the project



Mr. Razavi Project (Iran, Kerman, 12th Hezaroyekshab St.)

• Producer & The Contractor: Mousavi Group • The Employer & Architecture : Mr. Hossein Razavi

2. Detailed quotations

For any aspect or element of a new building or renovation, it is clearly vital to know what the cost is going to be. For stone architectural features, we can provide you with an accurate cost at the design stage assuming all details are available, or it may be possible to provide a budget price if they are not. For fully detailed quotations, we can use architects' designs, bills of quantity or, best of all, a stonework schedule. For budget costings we can work from basic information such as number and type of features that are likely to be required, along with length, breadth and height dimensions. A rough sketch always helps too. We cover every aspect of the job, and central to what we do is ensuring that there are no hidden extras for you. Every aspect is fully detailed to ensure you know exactly what the final total will be – assuming the requirements don't change of course. All quotations include dimensions of the products quoted and total weight of the items to be supplied. If material samples are needed, we can also supply these to show the colour and finish of the product quoted.



| Some details of the project



Facade of building- Building facade rendering



Building facade rendering



Facade of building

(Iran, Kerman, The intersection of Villa and Meysam St.) **Villa**

• Employer : Mr. Abdolalizade • The Architecture , The Producer & The Contractor: Mousavi Group



Light facade

3. Custom design

We very much specialise in the manufacture of individually designed stone features to meet specific project requirements. The overall design of these units comes either from architects' drawings, or from pictures you might provide. We are often asked to produce a design based on rough visuals, a variation of one of our standard products, or just from a verbal brief, and we always aim to help as much as we can. This approach of carrying out custom design for stone features is typically more cost effective for you, as our in-depth knowledge on a technical level means we are able to take all factors into account – not just aesthetics. These factors include the practicalities and economy of milling manufacture and stonework production, along with how the stonework design may impact on the build.



| Green and Slab walls in interior design



| Back facade structure VS Executed facade





Some examples of Stone Products (Villa)



Some examples of Stone Products (Villa)

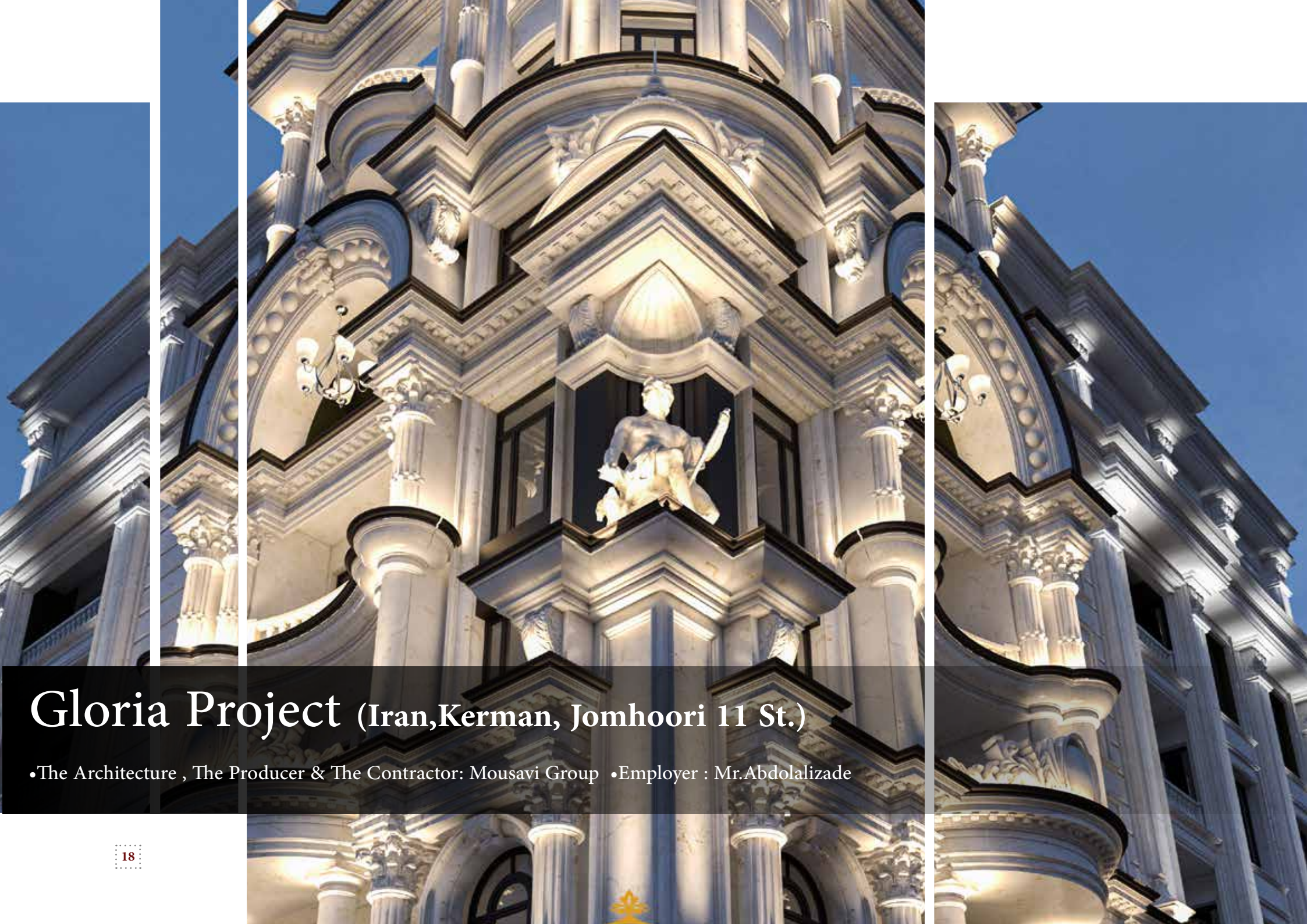

Gloria Project (Iran,Kerman, Jomhoori 11 St.)

•The Architecture , The Producer & The Contractor: Mousavi Group •Employer : Mr.Abdolalizade





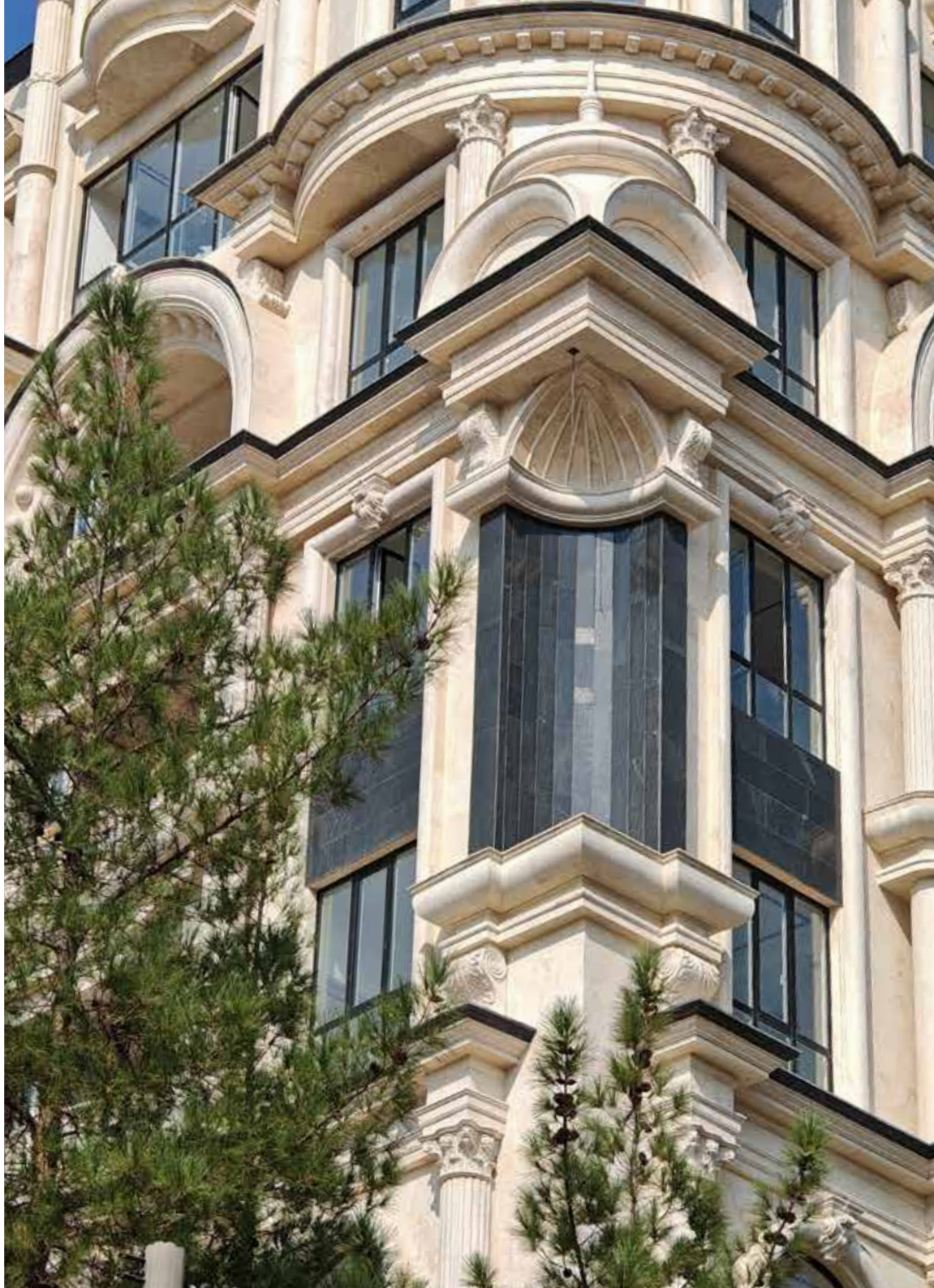

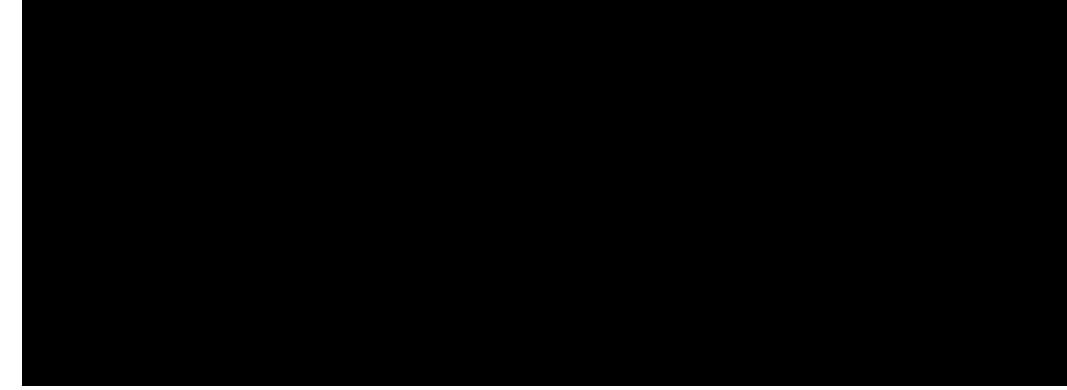

We do high-quality, large-scale projects, complex special shapes , handicrafts, ect . leave it to me and guarantee your satisfaction!







Mr. Jahanshahi Project (Iran, Kerman, Farabi St.)

•The Architecture , The Producer & The Contractor: Mousavi Group (Miss .PourTaheri) •Employer : Mr.Jahanshahi



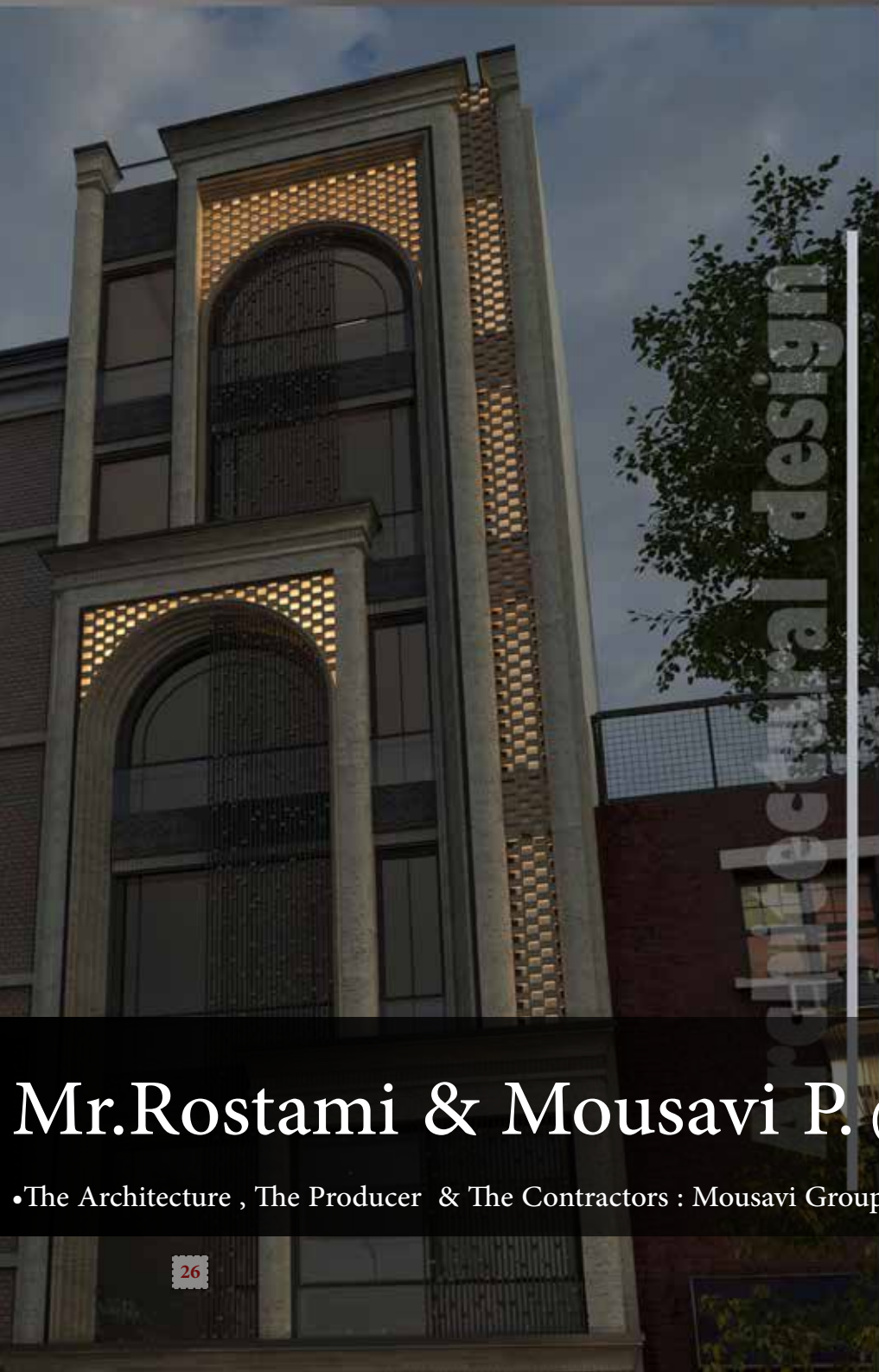

Mr.Rostami & Mousavi P. (Iran,Kerman, Keshavarz Blvd.)

•The Architecture , The Producer & The Contractors : Mousavi Group (Miss .Iranmanesh)



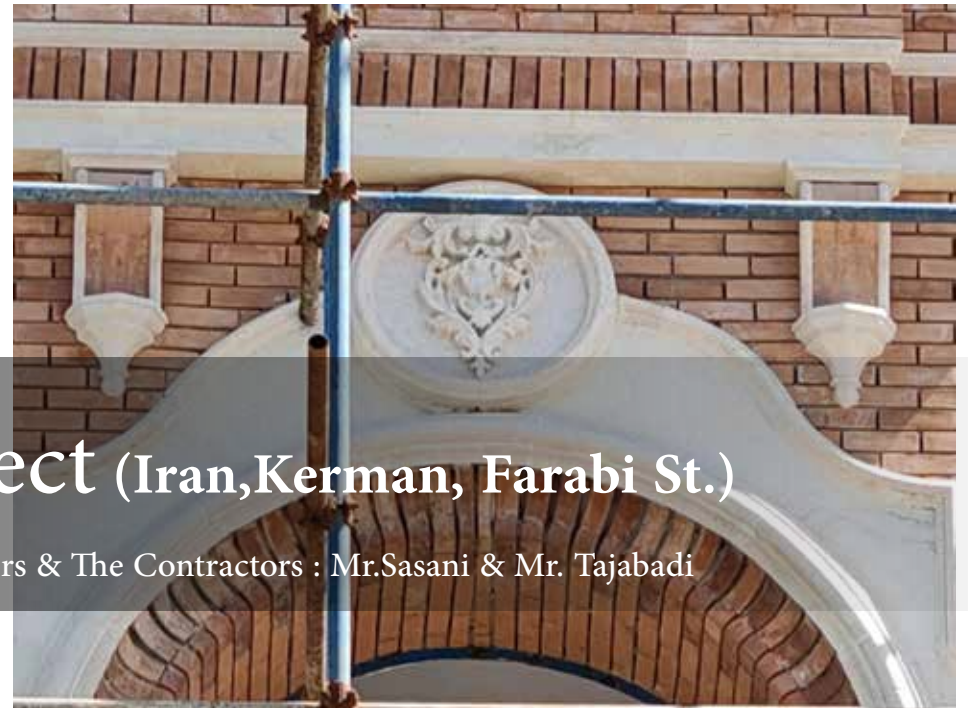

Mr. Sasani & Mr. Tajabadi Project (Iran, Kerman, Farabi St.)

• The Architecture, The Producer : Mousavi Group (Miss .Iranmanesh) • Employers & The Contractors : Mr. Sasani & Mr. Tajabadi





Raika residence -Alco group (Iran,Kerman, Abnous St.)

•The Architecture , The Producer & The Contractor: Mousavi Group •Employer : Alco Group (Mr.Amiri)





Raika residence - Alco group (Iran, Kerman, Abnous St.)

•The Architecture , The Producer & The Contractor: Mousavi Group •Employer : Alco Group (Mr.Amiri)





Mr. Abdolalizade (Iran, Kerman, 12th Hezaroyekshab St.)

•The Architecture , The Producer & The Contractor: Mousavi Group •Employer : Mr.Abdolalizade

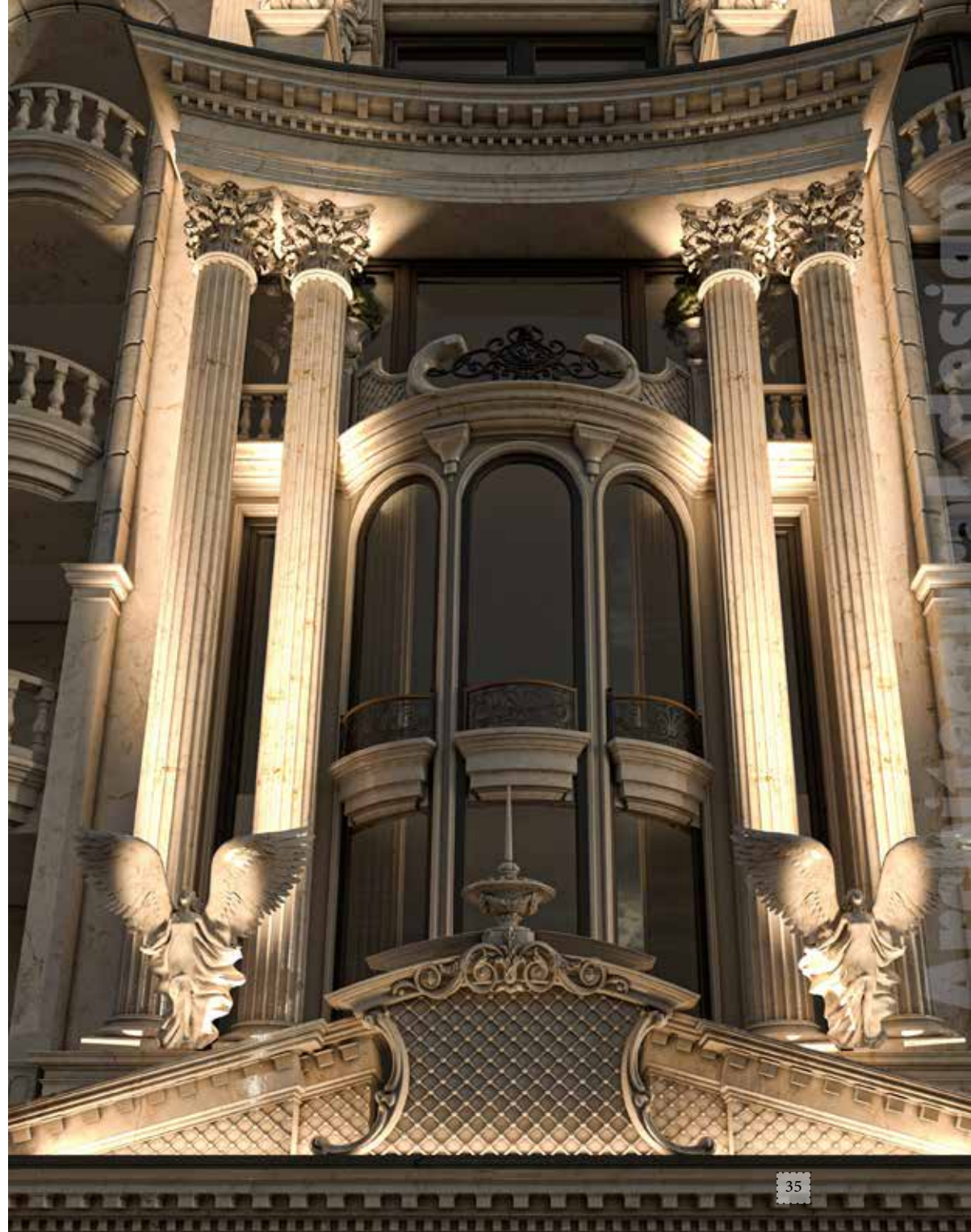



Mr. Abdolalizade (Iran, Kerman, 12th Hezaroyekshab St.)

•The Architecture , The Producer & The Contractor: Mousavi Group •Employer : Mr.Abdolalizade





Alton group (Iran,Kerman, Keshavarz Blvd.)

•The Architecture , The Producer : Mousavi Group •Employer & The Contractor: Alton Group (Mr.Abaszade)





Alton group (Iran,Kerman, Keshavarz Blvd.)

•The Architecture , The Producer : Mousavi Group •Employer & The Contractor: Alton Group (Mr.Abaszade)





Mr. SalarKarimi Project (Iran,Kerman, Valvajr Blvd.)

•The Producer : Mousavi Group •Employer & The Contractor: Mr. SalarKarimi •The Architecture : Mr. Oghianoosi

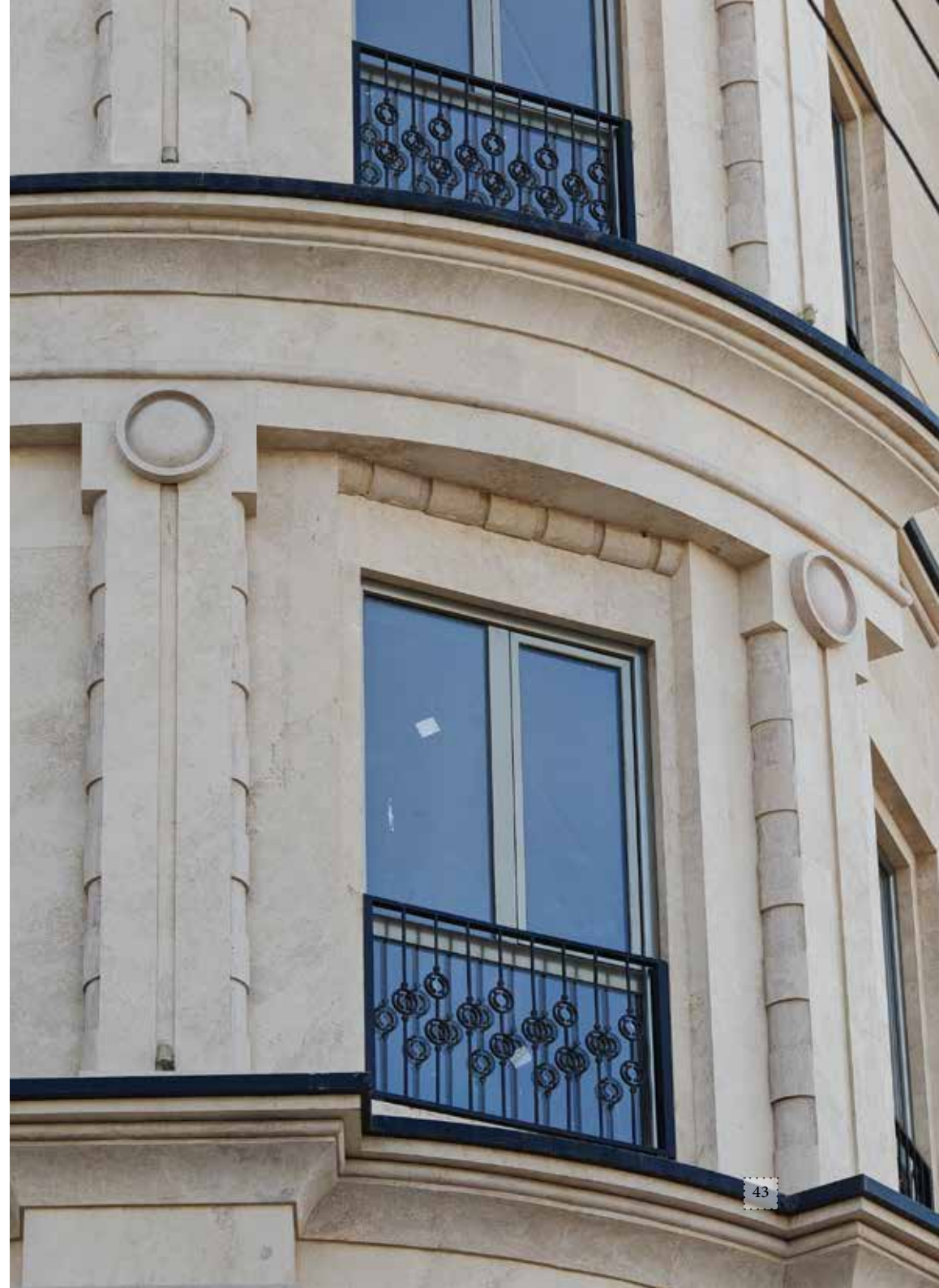

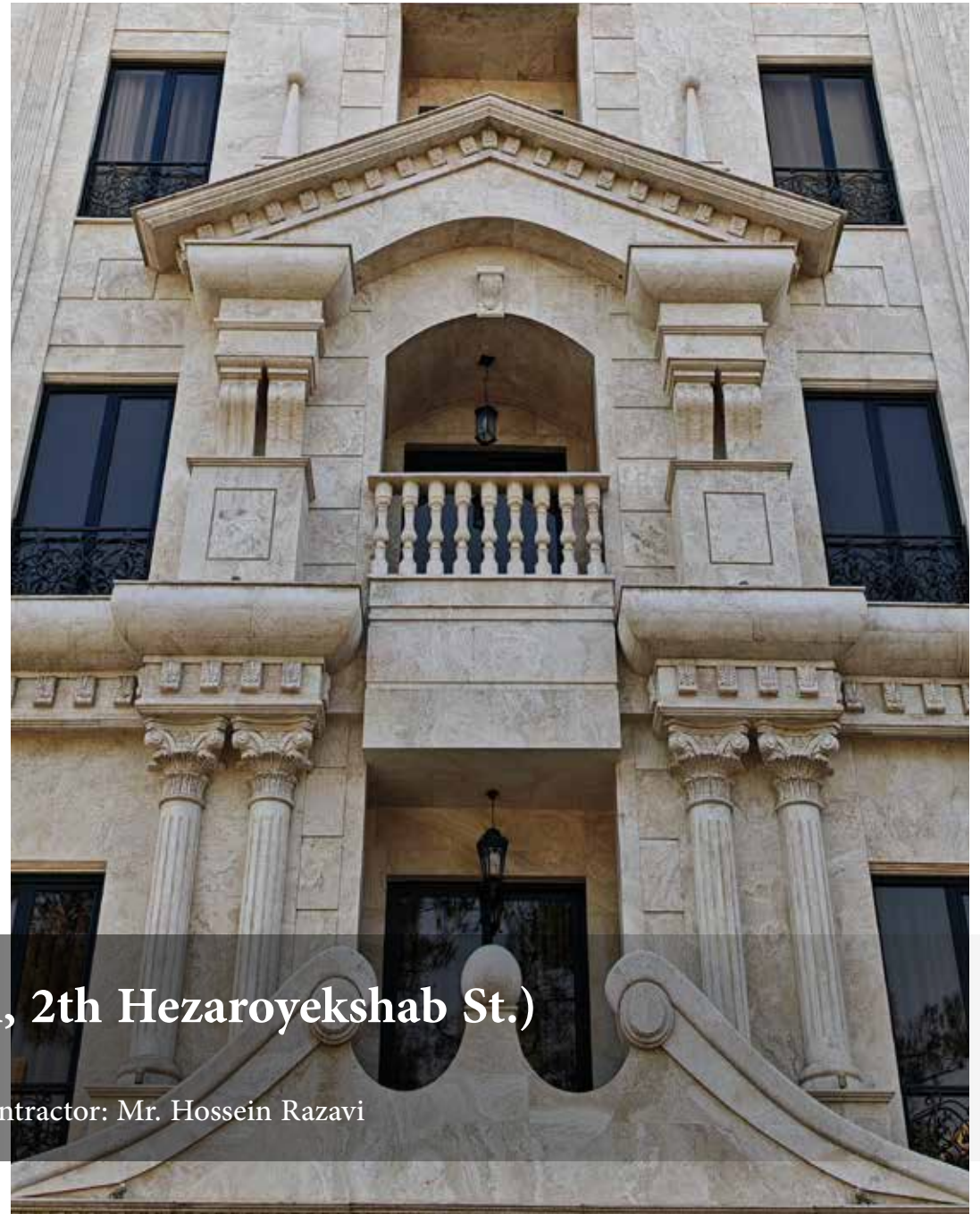

Mr. Razavi Project (Iran, Kerman, 2th Hezaroyekshab St.)

•The Producer : Mousavi Group •The Architecture & Employer & The Contractor: Mr. Hossein Razavi



(Iran, Kerman, 2th Hezaroyekshab St.) **Dr. Rahgozar & MR . Ebrahimi**

• Employer : Mr.Ebrahimi & Dr. Rahgozar • The Architecture & The Producer : Mousavi Group



Golden Grana -Alco group (Iran,Kerman, Farhangian St.)

•The Architecture , The Producer & The Contractor: Mousavi Group •Employer : Alco Group (Mr.Amiri)





Mr. Harandi Building



Mr. Noorzehi Building



Mr. Haeri Building



Mr. Rastegar Building

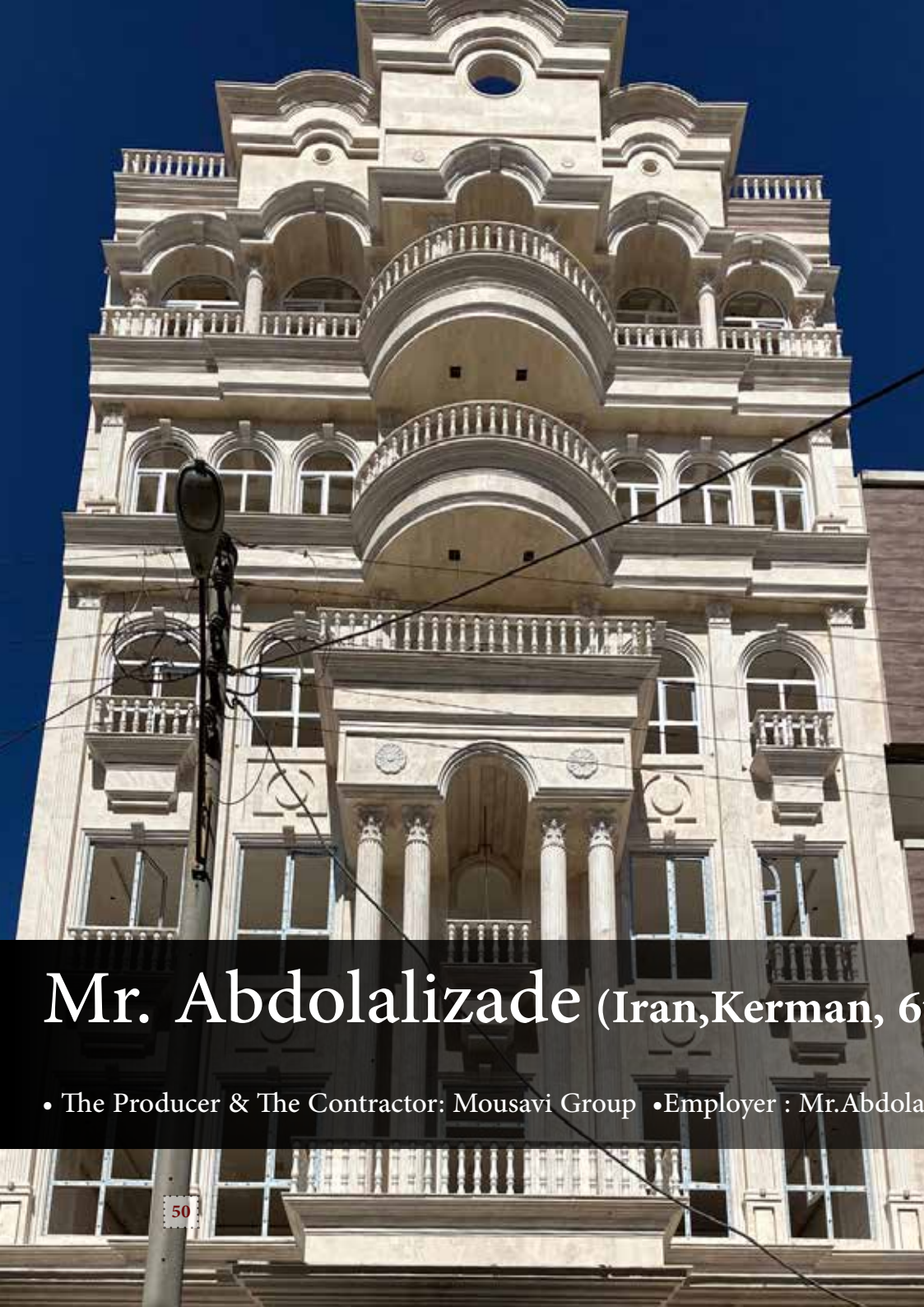

Mr. Abdolalizade (Iran, Kerman, 6th Emamjome St.)

• The Producer & The Contractor: Mousavi Group • Employer : Mr. Abdolalizade • The Architecture : Mr. Molai



4. Manufacture

There are four main stages to the manufacturing process:

- Cut Block Stones
- Milling Stones
- Polish Stones
- Final quality checks





5. Delivery

Although some of our customers may find it convenient to collect from our premises (in particular for standard products), generally speaking we deliver to site – and on a specified day to ensure the product is ready as part of your building schedule. We use our own lorries or trusted specialist delivery partners, which means there's a full understanding of how your product needs to be handled to ensure safety and preservation of perfect condition.



| Some details of the project

Mr. Hasani (Iran, Kerman, West Kosar blvd.)

• The Producer: Mousavi Group • Employer: Mr. Ranjbar • The Architecture: Mr. Peivand

6. Installation

For relatively simple stone features, perhaps a cill or head, it's generally the case that a building contractor will have all the necessary skills to install them properly. However, for more complex features – e.g. a portico or balustrading – our customers often prefer to use our own directly employed expert installation team. By retaining us as a specialist installer you can be sure that we will get the job right first time. This can, in the long run, save money and lower the risk of using someone whose experience in handling and installing stone is limited. There's also the advantage that the stone feature or features remain our responsibility right up until the installation is complete and signed off. In this respect, there's the added reassurance of knowing that the investment remains secure throughout the installation.



| Some details of the project





Royal Palace (Iran, Kerman, 4th Hezaroyekshab St.)

•The Architecture , The Producer & The Contractor: Mousavi Group •Employer : Mr.Abdolalizade



Installation





Facade of building

Mr. Kheikhah (Iran, Kerman, 25th Valvajr St.)

•The Architecture , The Producer & The Contractor: Mousavi Group •Employer : Mr.Kheirkhah



Building facade rendering



Dr. Ebrahimi (Iran, Kerman, Hezaroyeshab St.)
•The Architecture , The Producer & The Contractor: Mousavi Group (Miss. Iranmanesh)





|Project and Design gallery





We think it's fair to say that, over the years, we've gained an outstanding reputation for turning clients' ideas and concepts into the highest quality stone architectural features. We've achieved this through the skills and vast experience of our designers, Milling Machines and dedicated production and installation teams. Here are some of the amazing Products And Design we have done!.



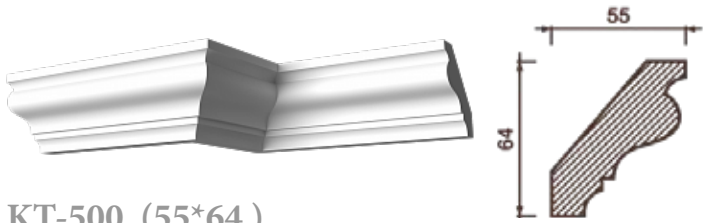
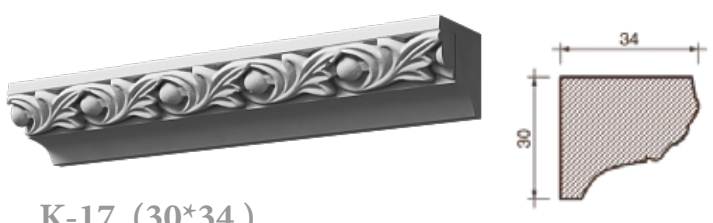

Some products List

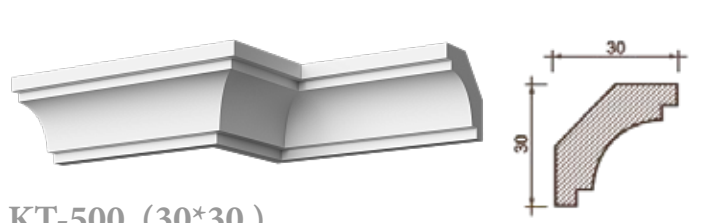
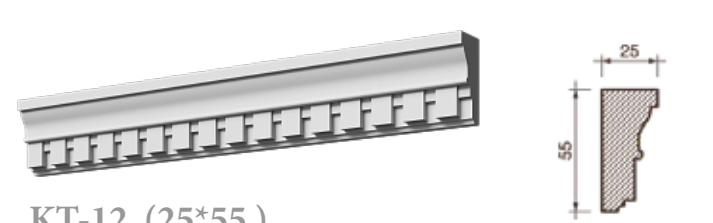
We Hold a large range of high quality standard stone products ready for collection or can quickly produce if more are needed or a special colour is required etc. Some of our products are listed in the table below. for more Models u can contact us .

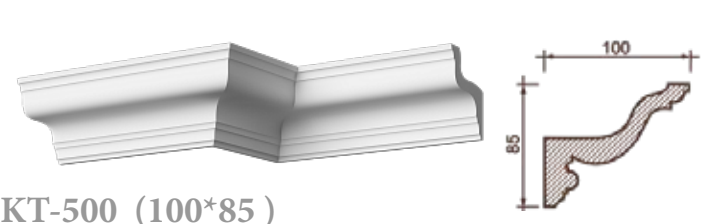
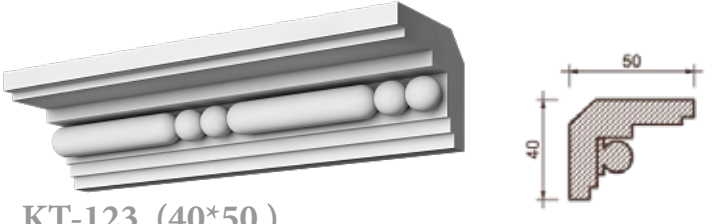
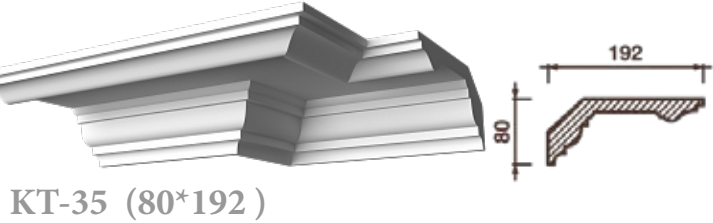
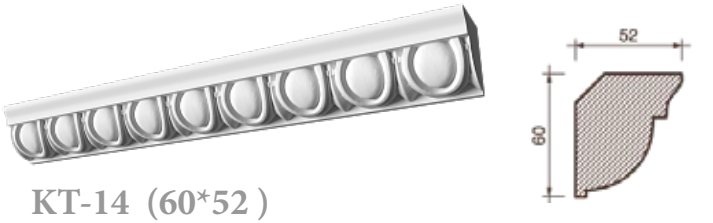
SMOOTH RODS	 <p>KT-500 (55*64)</p>	KARINIZI WITH FIGURE	 <p>K-17 (30*34)</p>	SCULPTURES	 <p>Scpt-1</p>
	 <p>KT-500 (30*30)</p>		 <p>KT-12 (25*55)</p>		 <p>Scpt-2</p>
	 <p>KT-500 (100*85)</p>		 <p>KT-123 (40*50)</p>		
	 <p>KT-35 (80*192)</p>		 <p>KT-14 (60*52)</p>		

SOCKETS

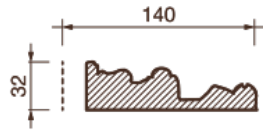

P-54 (32*140)



P-54 (24*276)



P-38 (38*250)



P-94 (38*250)

CUTTERS

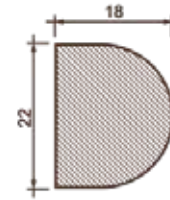

N-108 (22*18)

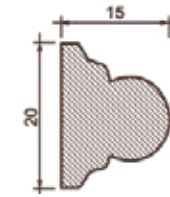
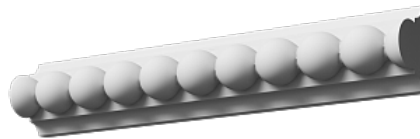

N-38 (20*15)



N-59 (42*9)

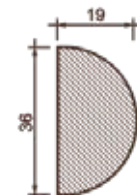
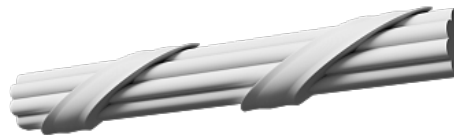

N-55 (19*38)

SCULPTURES



C-83 (117*120*35)



Scpt-3



Sculptures



We do high-quality, large-scale projects, complex special shapes , handicrafts, ect . leave it to me and guarantee your satisfaction!



Sculptures





Design (facade, Interior and outdoor)

Mr.Moein Nia (Iran,bam)

•The Architecture :

Miss. PourTaheri (Mousavi Group)





Mr. Abdolalizade (Iran, Kerman, 12th Hezaroyekshab)

• The Architecture : Mojtaba Mousavi (Mousavi Group)







Mr. Mohammadi (Iran, Kerman, Komeyl St.)

• The Architecture : Mr. Mojtaba Mousavi

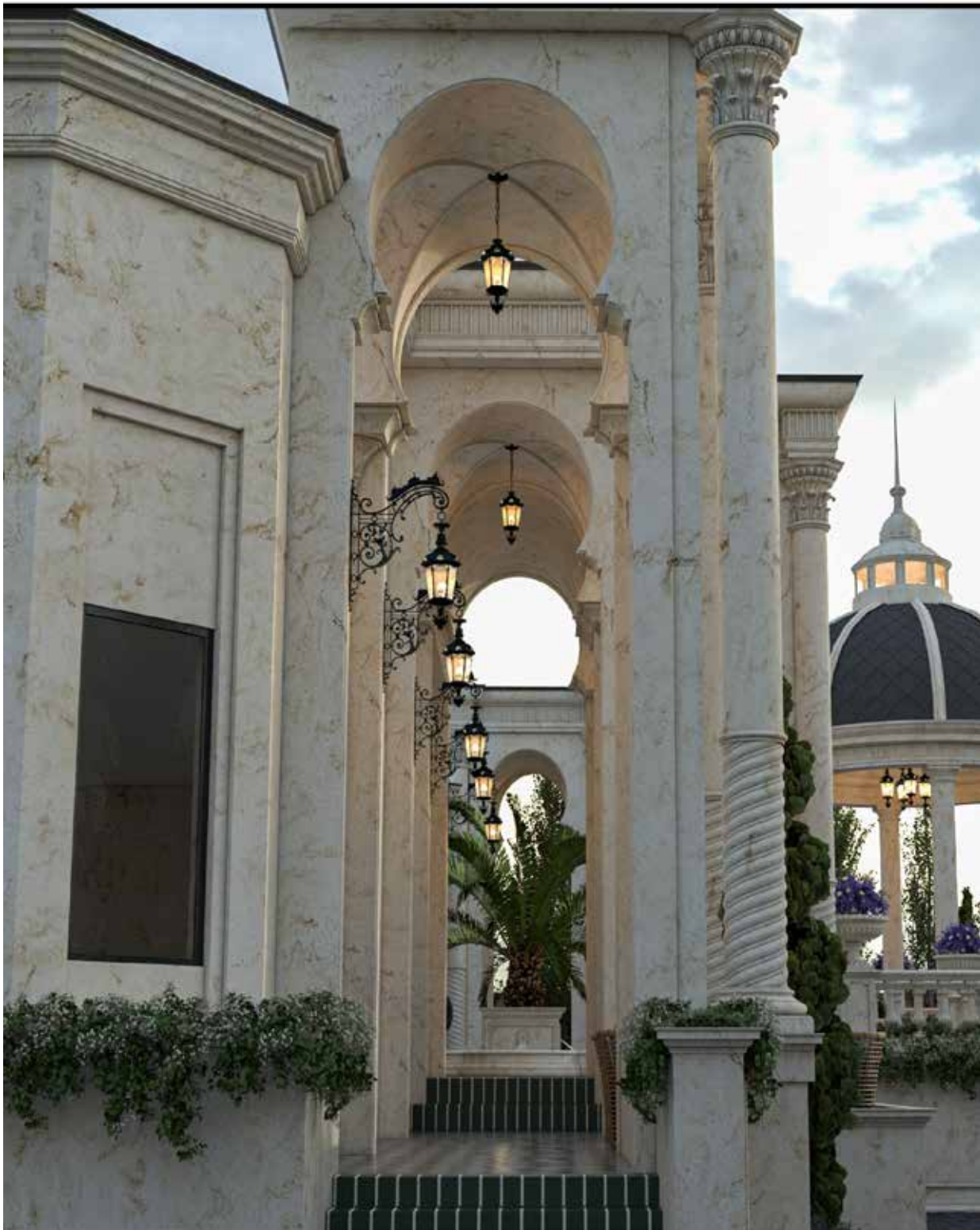



Mr. Abdolalizade (Iran, Kerman, 12th Hezaroyekshab)

• The Architecture : Miss. Iranmanesh (Mousavi Group)



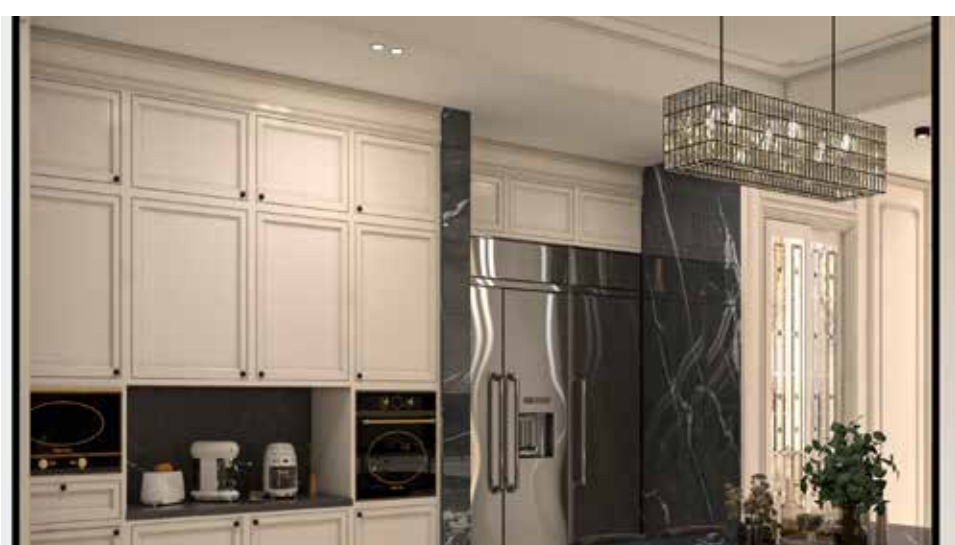

Dr. Ebrahimi (Iran, Kerman, Hezaroyekshab St.)

• The Architecture : Miss. Iranmanesh (Mousavi Group)



The Architecture :
Mr. Miss Iranmanesh
(Mousavi Group)

Project :
Dr. Ebrahimi
South View





•The Architecture :
Mr. Mojtaba Mousavi
Project :Abnous (Mr.Abdolizade)



Mr .Khaje hasani

(Iran,Kerman, Haft Bagh)

•The Architecture :

Miss. PourTaheri

(Mousavi Group)



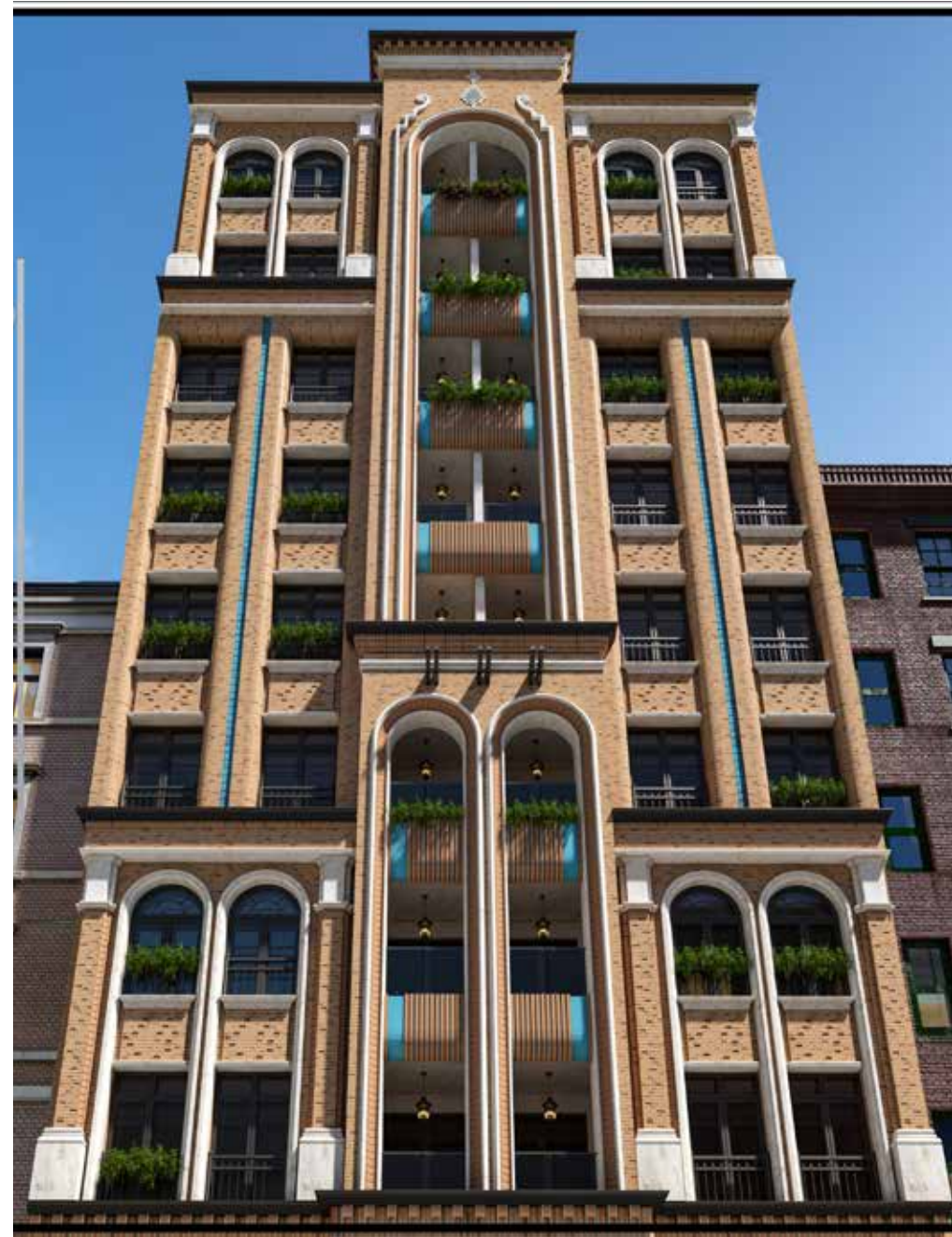

Mr. Jahangiri - Toop 24 (Iran, Kerman, 25th Valvajr St.)

•The Architecture : Miss. Pour Taheri (Mousavi Group)



Mr. Mirahmadi (Iran, Kerman, Shahrak Bahonar)

• The Architecture : Miss. Pour Taheri (Mousavi Group)

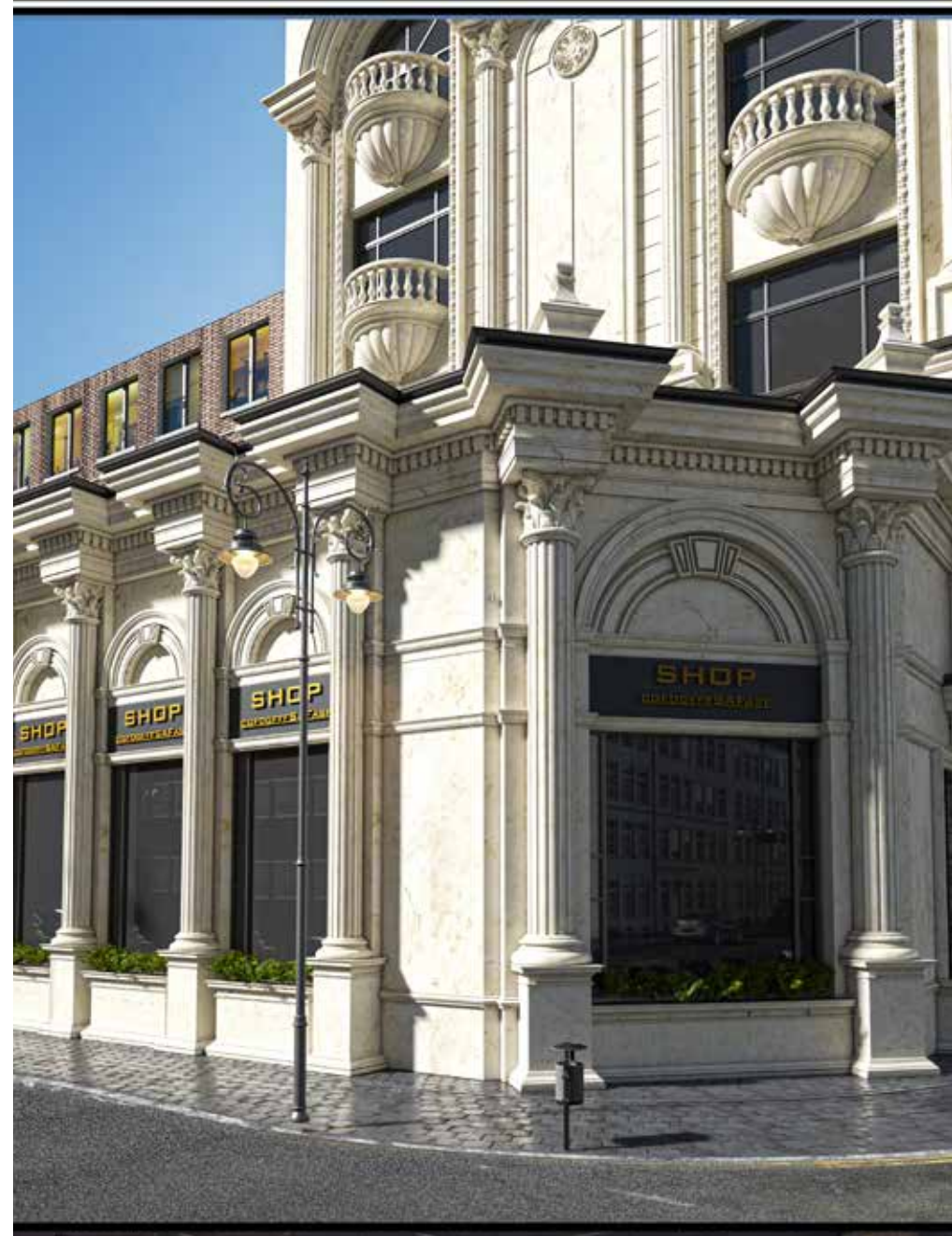

Mr. Malekshahi (Iran, Sirjan)

• The Architecture : Miss. Pour Taheri (Mousavi Group)



Dr. Mohammadi (Iran, Kerman, Jomhoori Blvd.)

• The Architecture : Miss. Pour Taheri (Mousavi Group)



Dr. Mohammadi (Iran, Kerman, Jomhoori Blvd.)

•The Architecture : Miss. PourTaheri (Mousavi Group)



Mrs. Ezat Doost (Iran, Kerman, Haft Bagh)

• The Architecture : Mr. Mojtaba Mousavi (Mousavi Group)



Cinema



Gaming Room



Interior Desgin

•The Architecture : Miss. PourTaheri (Mousavi Group)



Interior Desgin

The Architecture :
Miss. PourTaheri
(Mousavi Group)

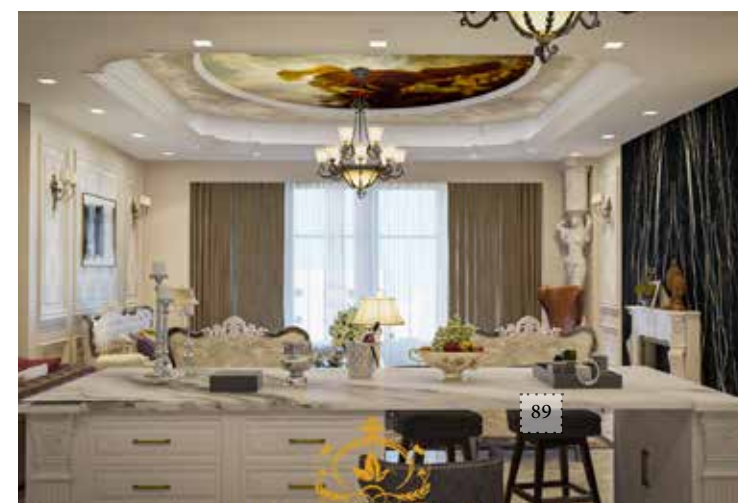

Hall Room



Mr. Afzali (Rollex P.)

•The Architecture : Miss . PourTaheri (Mousavi Group)



Parking Room

Interior Desgin

•The Architecture :
Miss. PourTaheri



Roof Garden



Lobby Room

WC



Lobby



Working Room



Bed Room



Mr. Mohammadi

•The Architecture : Mrs. Ameri (Mousavi Group)



Mr. Afzali (Rollex P.)

- The Architecture :
Mrs. Ameri (Mousavi Group)



Mr. Bahrami
•The Architecture : Mr. Mousavi & Miss. PourTaheri (Mousavi Group)





Mr. Bahrami

•The Architecture : Mr. Mousavi & Miss. PourTaheri (Mousavi Group)





Mr. Bahrami
•The Architecture : Mr. Mousavi & Miss. PourTaheri (Mousavi Group)





Mr. Bahrami

•The Architecture : Mr. Mousavi & Miss. PourTaheri (Mousavi Group)



Contact US:

| Address:

Iran,kerman, Khazra Industrial Town,
Yaseman Street , Corner of 4'Th Street

| Telephone:

+98-9133408571
+98-9132998507
+98-9133878098

| E-mail:

Mneverhood@gmail.com

| Website:

www.kss.ir

| Instagram:

@Nasr_Stone
@Mousavi.group





طراحی ، تولید و اجرای خانه شما

آدرس : کرمان ، شهرک صنعتی شماره 2 ، نبش یاسمن چهارم | شماره تماس : 09133878098 09133408571 09132998507
سایت : www.Mousavi.company | اینستاگرام : [Mousavi.Group@ Nasr_Stone@](mailto:Mousavi.Group@Nasr_Stone@)

